

Features

- On Chip Hall Sensor
- Rotor-Locked Shutdown
- Automatically Restart
- Rotor-State Detection (RD) Output
- Built-in Zener Protection for Output Driver
- Operating Voltage: 1.8V~5.75 V
- Output Current: $I_{O(AVE)} = 400 \text{ mA}$
- Lead Free Finish/RoHS Compliant for Lead Free products (Note 1)
- Packages: SOT25 and SOT89-5L

General Description

AH293 is a monolithic fan motor controller with Hall sensor's capability. It contains two complementary open-collector transistors for Motor's coil driving, automatic lock current shutdown, and recovery protections. Also, rotor-state detection (RD) output is for speed detection.

Rotor-lock shutdown detection circuit turns off the output driver when the rotor is blocked to avoid coil overheat. Then, the automatic recovery circuit will restart the motor. These protected actions are repeated and periodic during the blocked period. Until the blocking is removed, the motor recovers and runs normally.

Ordering Information

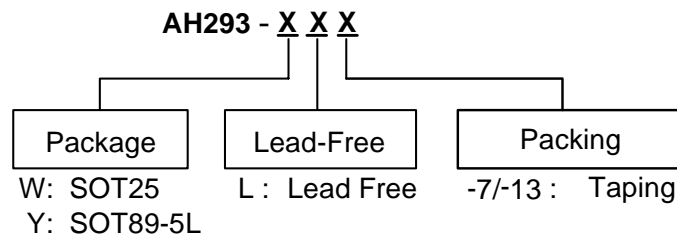

Note: 1. RoHS revision 13.2.2003. Glass and High Temperature Solder Exemptions Applied, see *EU Directive Annex Notes 5 and 7*.

Device	Package Code	Packaging (Note 2)	7" Tape and Reel	
			Quantity	Part Number Suffix
AH293-W	W	SOT25	3000/Tape & Reel	-7
AH293-Y	Y	SOT89-5L	2500/Tape & Reel	-13

Note: 2. Pad layout as shown on Diodes Inc. suggested pad layout document AP02001, which can be found on our website at <http://www.diodes.com/datasheets/ap02001.pdf>.

Pin Assignment

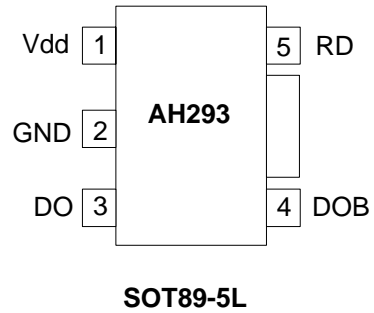
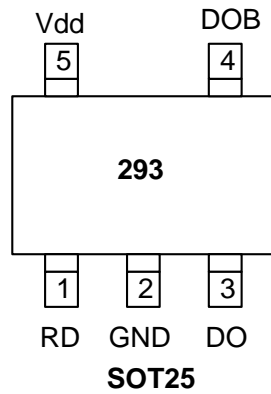

Pin Descriptions

Symbol	Description
RD	Rotor-State Detection
V _{dd}	Input Power
DO	Output Pin
DOB	Output Pin
GND	Ground

Block Diagram

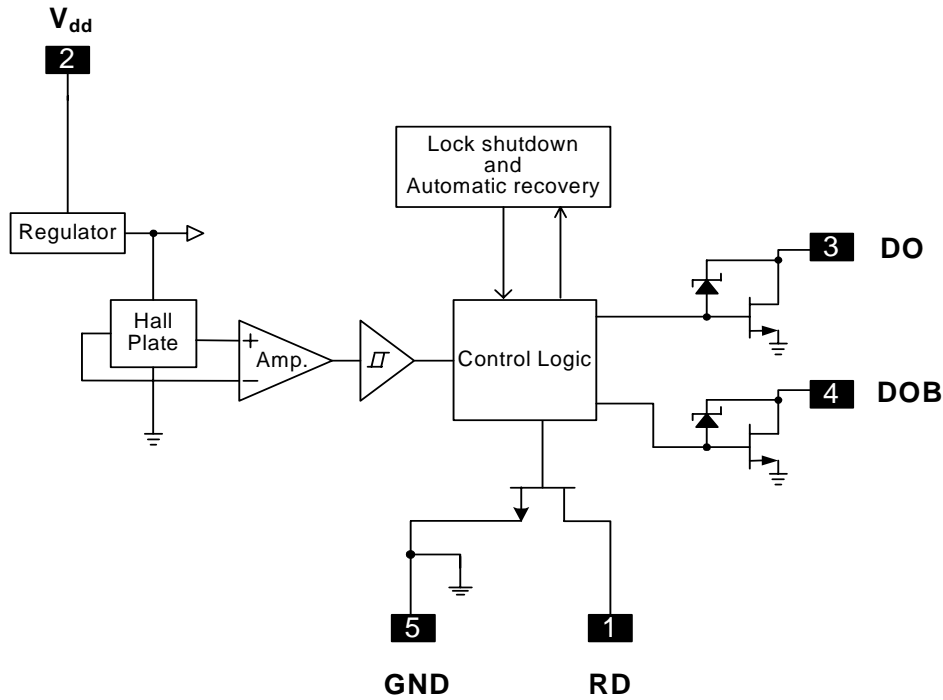

Typical Application Circuit

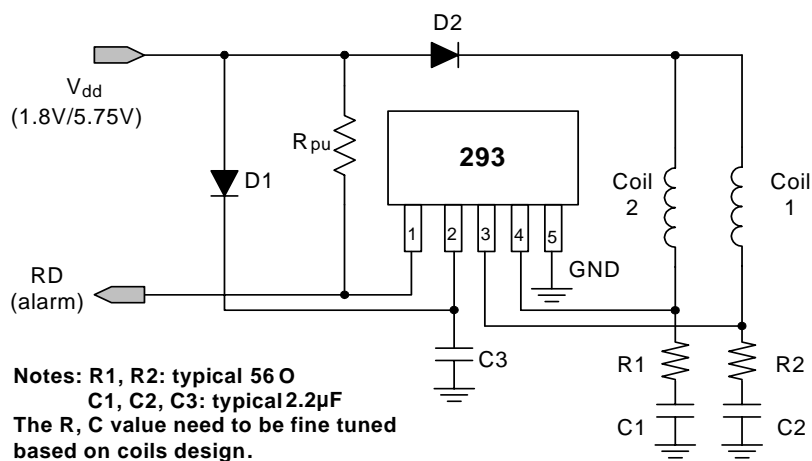

1.8V/5.75V DC Brush-Less Fan with RD Output Function

Absolute Maximum Ratings ($T_A = 25^\circ\text{C}$)

Characteristics	Symbol	Rating	Unit
Operating Supply Voltage	Vdd	8	V
Output Current	$I_{O(AVE)}$	400	mA
	$I_{O(PEAK)}$	700	
Power Dissipation	P_D	SOT25	230
		SOT89-5L	800
Operating Temperature	T_{opr}	-20 ~ 100	$^\circ\text{C}$
Storage Temperature	T_{stg}	-55 ~ 150	$^\circ\text{C}$
Maximum Junction Temperature	T_j	150	$^\circ\text{C}$

Electrical Characteristics ($T_A = 25^\circ\text{C}$, Vdd = 5V, unless otherwise specified)

Characteristics	Symbol	Conditions	Min.	Typ.	Max.	Unit
Supply Voltage	Vdd	Operating	1.8*	-	5.75	V
Supply Current	Idd	Operating	-	2.6	4.0	mA
Locked Protection On	Tlrp-on		-	0.4	-	Sec
Locked Protection Off	Tlrp-off		2.4	3	3.6	Sec
Output Saturation Voltage	$V_{OUT(sat)}$	$I_O = 180\text{mA}$	-	300	-	mV
		$I_O = 350\text{mA}$	-	600	-	
Output On Resistance	Rds(on)		-	1.75	-	ohm
RD Output Vds	Vol	$I_O = 10\text{mA}$	-	0.5	-	V
Output Zener-Breakdown Voltage	Vz		-	15	-	V

*Note: The output of IC will be switched after the supply voltage is over 1.8V, but the magnetic characteristics won't be normal until the supply is over 2.0V.

Truth Table

IN-	IN+	CT	OUT1	OUT2	RD	Mode
H	L	L	H	L	L	Rotating
L	H	L	L	H	L	Rotating
-	-	H	off	off	off	Lockup protection activated

Latch-type RD output is low during rotation and high during stop

Magnetic Characteristics ($T_A = 25\text{ }^\circ\text{C}$, $V_{dd} = 5\text{V}$, unless otherwise specified)

(1mT = 10 Gauss)

Characteristics	Symbol	Min.	Typ.	Max.	Unit
Operation Point	Bop	--	30	60	Gauss
Release Point	Brp	-60	-30	--	Gauss
Hysteresis	Bhy	--	60	--	Gauss

Operating Characteristics

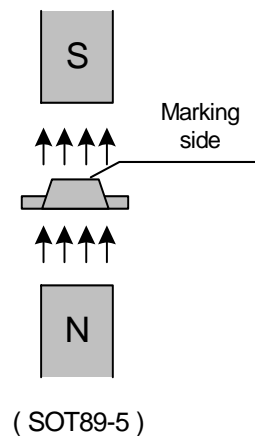
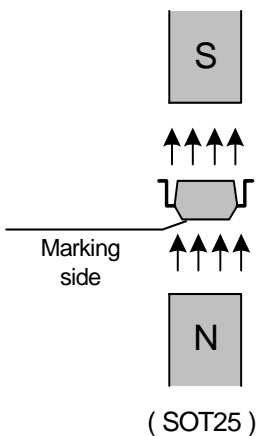
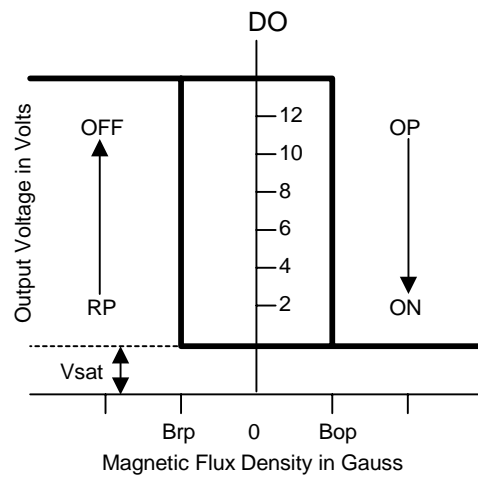
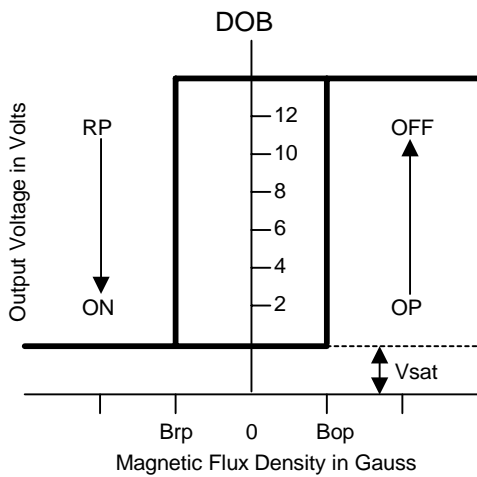

Performance Characteristics

(1) SOT25

T _A (°C)	25	50	60	70	80	90	100	110	120	130	140	150
P _D (mW)	230	184	166	147	129	110	92	74	55	37	18	0

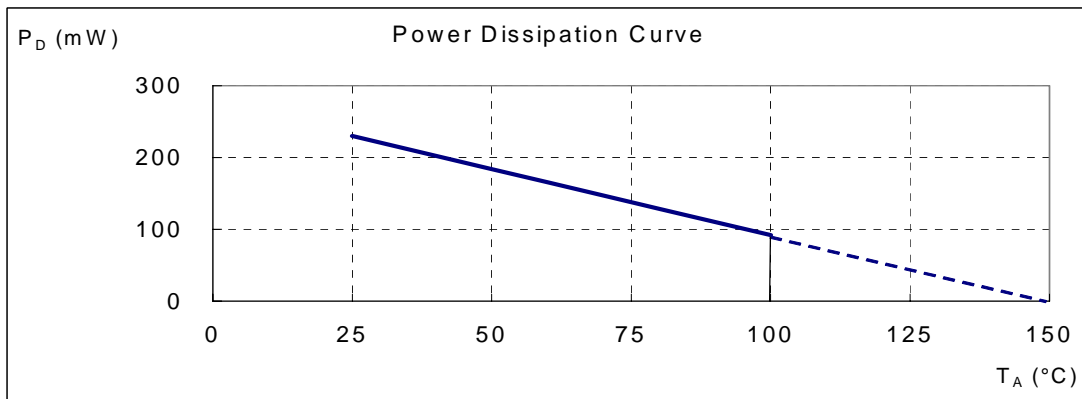

(2) SOT89-5L

T _A (°C)	25	50	60	70	75	80	85	90	95	100
P _D (mW)	800	640	576	512	480	448	416	384	352	320
T _A (°C)	105	110	115	120	125	130	135	140	145	150
P _D (mW)	288	256	224	192	160	128	96	64	32	0

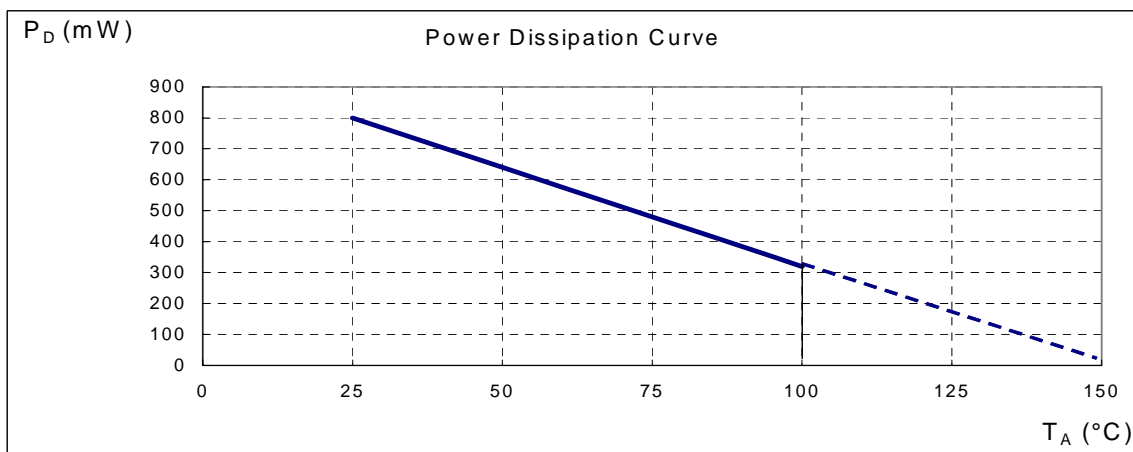

Marking Information

(1) SOT25

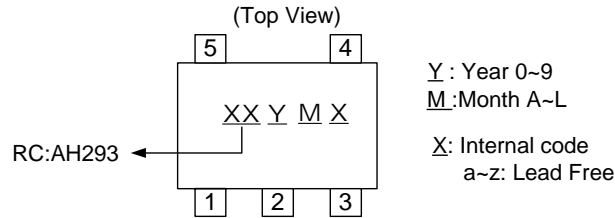

(2) SOT89-5L

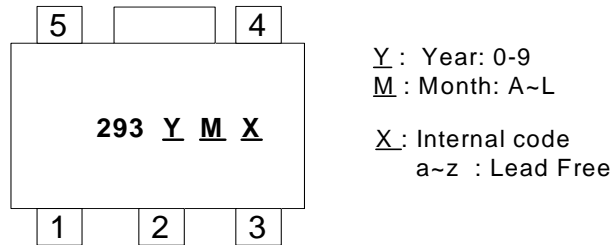

Package Information (unit:mm)

(1) SOT25

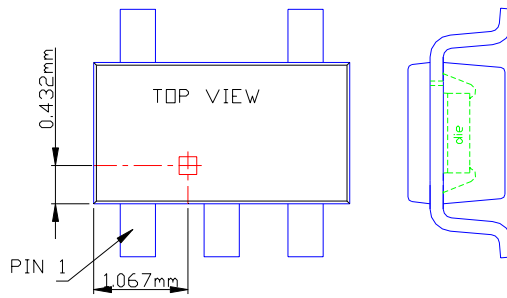
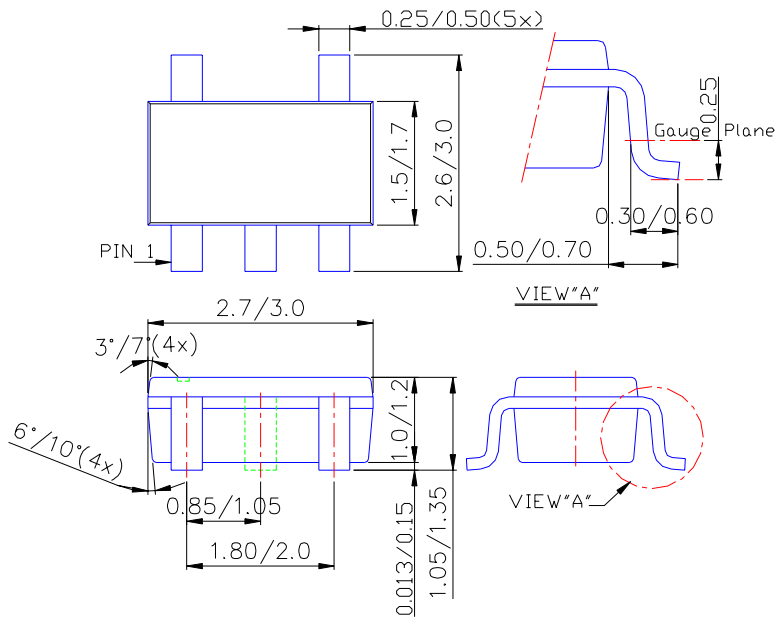

Sensor Location

Package Information (Continued)

(2) SOT89-5L

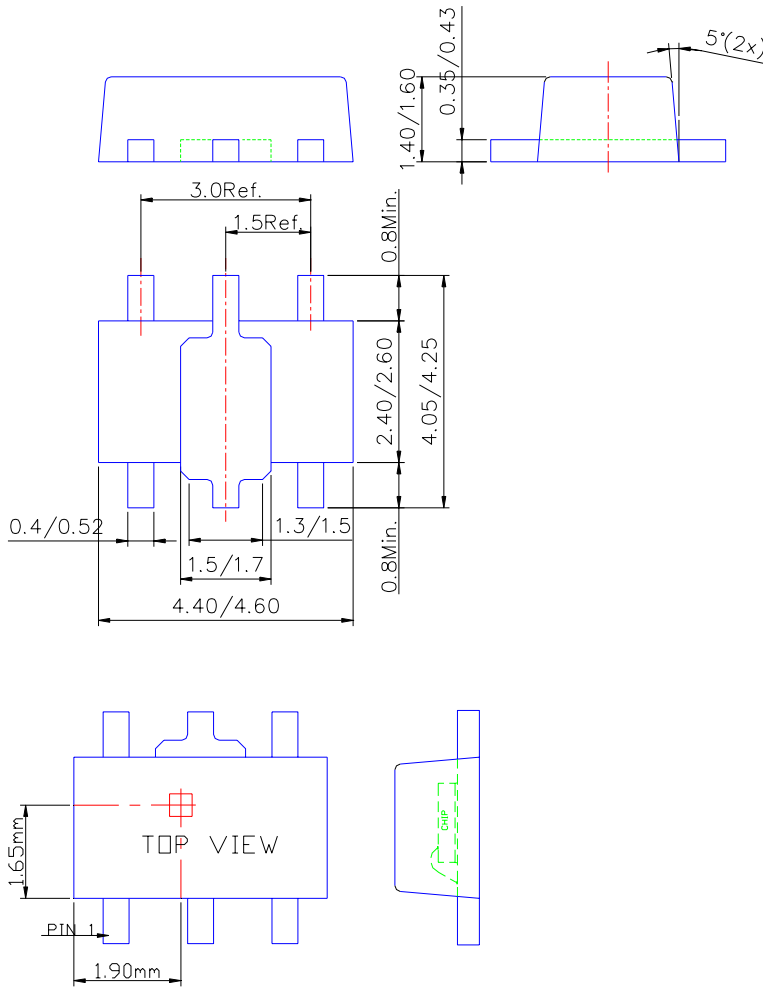

Sensor Location

IMPORTANT NOTICE

Diodes Incorporated and its subsidiaries reserve the right to make modifications, enhancements, improvements, corrections or other changes without further notice to any product herein. Diodes Incorporated does not assume any liability arising out of the application or use of any product described herein; neither does it convey any license under its patent rights, nor the rights of others. The user of products in such applications shall assume all risks of such use and will agree to hold Diodes Incorporated and all the companies whose products are represented on our website, harmless against all damages.

LIFE SUPPORT

Diodes Incorporated products are not authorized for use as critical components in life support devices or systems without the expressed written approval of the President of Diodes Incorporated.